

**TAMARACK QUICK CHANGE BARS**

patents 5,086,683 5,211,096 5,224,408 EP 0 552 396 B1

Please fill in as completely and accurately as possible:

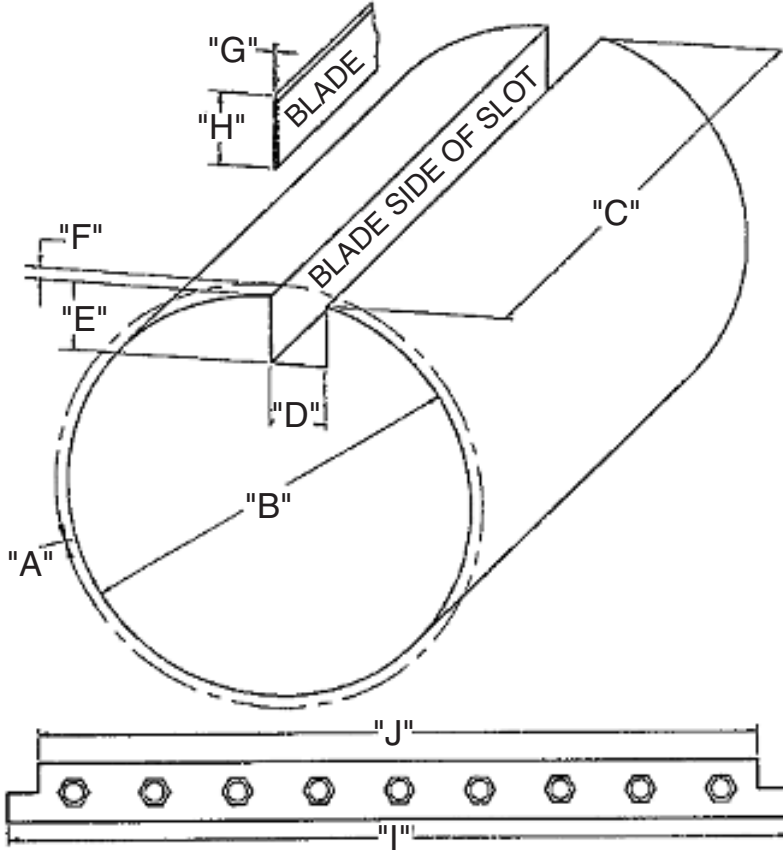

COMPANY:

ADDRESS:

CONTACT:

PHONE:

FAX:

PRESS/COLLATOR:

include serial no. & model no. if known)

QTY. BARS NEEDED:

QTY. OPERATOR TOOL KITS:

INSTALLATION KIT NEEDED? (yes/no)  
 (drill jig, tap guide, drill, tap)

Maximum web speed

\*= Critical dimension to be measured to high accuracy ( $\pm 0.003$ ").

A

Cut circumference (e.g. 22", 24", etc.)

\*D

Width of slot

G

Thickness of blade

B

Actual body diameter

\*E

Depth of slot

H

Height of blade

C

Length of slot

\*F

Blade extension (above cylinder body)

I

Max length of old bar

J

Min length of old bar

Please sketch your existing retention method on the views below. Also show any unique features such as rounded slot corners, not-flat slot bottom, etc.

